

● 機械規格：MACHINE SPECIFICATIONS

項目	ITEM		PLG-42	PLG-42L	PLG-52	PLG-60	PLG-75
最大加工外徑(配三爪)	Max. machining dia. (with 3 jaws chuck)	mm	Ø130	Ø130	Ø300	Ø380	Ø380
最大加工長度	Max. machining length		棒材外徑 x 3 / Bar diameter x 3				
(配尾座)---擲式	(with tail-stock)---Gang Type	mm	220	220	480	480	480
(選配刀塔)	(Opt. Turret)	mm	160	160	420	400	400
旋徑	Swing	mm	160	160	200	200	200
X軸行程	X Axis Travel	mm	230	300	310	310	300
Z軸行程	Z Axis Travel	mm	250	250	520	520	520
(選擇側面鑽銑)	(Opt. Radial Power Tools)	mm	—	190	—	—	—
主軸貫通孔徑	Spindle Hole	mm	55	55	60	85	85
棒材容納直徑	Bar Capacity	mm	42	42	52	60	75
主軸鼻端	Spindle Nose		A2-5	A2-5	A2-6	A2-6	A2-8
主軸夾頭	Spindle Chuck	inch	6"	6"	8"	10"	10"
主軸馬達	Spindle Motor		5.5kW/7.5HP	5.5kW/7.5HP	7.5kW/10HP	11.5kW/15HP	11.5kW/15HP
X軸馬達	X axis Motor		1kW	1kW	1.5kW	1.5kW	1.5kW
Z軸馬達	Z axis Motor		1kW	1kW	1kW	1kW	1kW
端/側動力鑽銑馬達(選配)	Axial / Radial Power Tools Motor (Opt.)		—	4kW	4kW	4kW	4kW
動力刀塔鑽銑馬達(選配)	Driven Tools Motor for Power Turret		2.2kW/3HP	2.2kW/3HP	3.7kW/5HP	3.7kW/5HP	3.7kW/5HP
主軸轉速	Spindle Speed	rpm	100-6000	100-6000	100-4000	100-3500	100-3000
快速位移(X,Z軸)	Rapid traverse (X, Z axes)	m/min	16	16	12	12	12
最小輸入單位	Min. Input Unit	mm	0.001	0.001	0.001	0.001	0.001
使用刀具(選配動力刀塔)	Cutting tool size (Opt. power turret)	mm	□20 (□16)	□20 (□16)	□25 (□20)	□25 (□20)	□25 (□20)
最大擱孔刀具	Max. Bore Size of Tools	mm	Ø25	Ø25	Ø32	Ø32	Ø32
冷卻幫浦馬達	Coolant Pump Motor	HP	1/4	1/4	1/4	1/4	1/4
機械尺寸(不含排屑機)	Machine Dimension (without Chip Conveyor)	cm	215x143x199	215x158x199	263x170x194	263x170x194	263x170x194
機械淨重	Machine Weight	kgs	1780	1850	3000	3180	3280

※因長期研發，機械設計如有變更恕不另行通知。

● POLY GIM Machine Co., Ltd. and it's association reserves the right to alter any mechanical specification without prior notice in the interest of product development.

● 標準配件 STANDARD ACCESSORIES

- 控制器：三菱 Controller : Mitsubishi 一套 1 set
- 三爪油壓夾頭 3-jaw hydraulic chuck 一個 1 pc
- 夾頭腳踏開關 Foot chuck switch 一個 1 pc
- 工作燈 Working Light 一個 1 pc
- 工具及工具箱 Tools & tool box 一組 1 set
- 冷卻系統 Coolant system 一組 1 set
- 櫛式刀盤 Gang type tool disc 一個 1 pc
- 機械墊塊 Leveling bolts and pads 六個(42型) 4個 6 pcs (type 42 with 4 pcs)
- 內孔刀座 Boring tool holder 三個 3 pcs
- 內孔單刀架襯套 Tool holder bushing 8mm, 10mm, 12mm, 16mm, 20mm (42型) 各二個 2 pcs/ea (type 42)
8mm, 10mm, 12mm, 16mm, 20mm, 25mm (52/60/75型) 各二個 2 pcs/ea (type 52/60/75)
- 外徑上下刀座 O.D turning upper and lower tool holders 四個 4 pcs

★ 選配刀塔則無此配置 If option turret will without this accessories

● 選擇配件 OPTIONAL ACCESSORIES

(PLG-42/52/60/75)

- 八角油壓刀塔 8-stations hydraulic turret
- 排屑機 + 鐵屑車 Chip conveyer+Bucket
- 成品收集器或成品輸送裝置 Part catcher or Part conveyer
- 尾座 (移動方式為手調) Tail-stock (movement is manual)

(PLG-42L)

- 八角伺服刀塔 8-stations servo turret
- 2孔側面鑽銑刀具刀座 2 pcs radial drilling tool holder
- 3孔端面鑽銑刀具刀座 3 pcs axial drilling tool holder
- 成品輸送裝置 Part conveyer
- 排屑機+鐵屑車 Chip conveyer+Bucket

● 刀具行程 TOOLING DIAGRAM

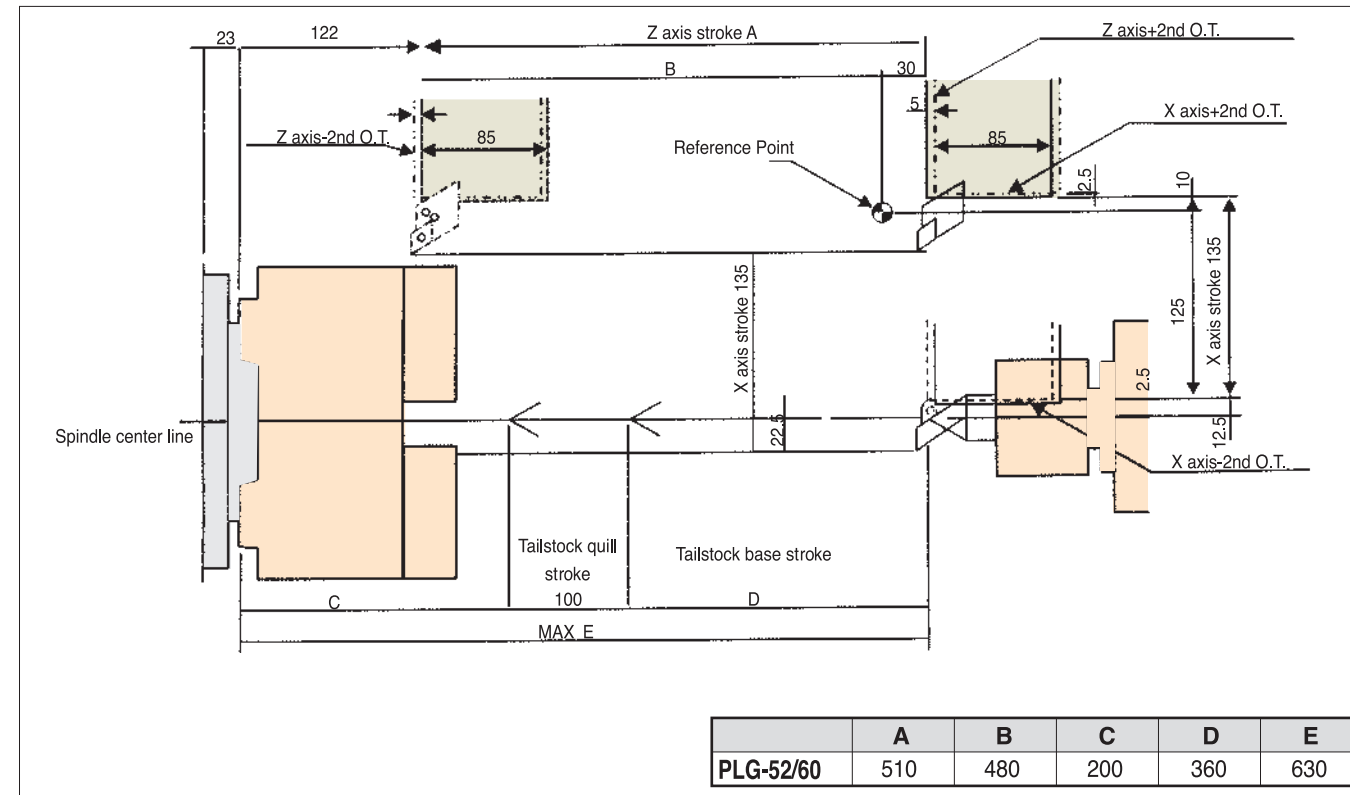

● 櫛式工具 GANG

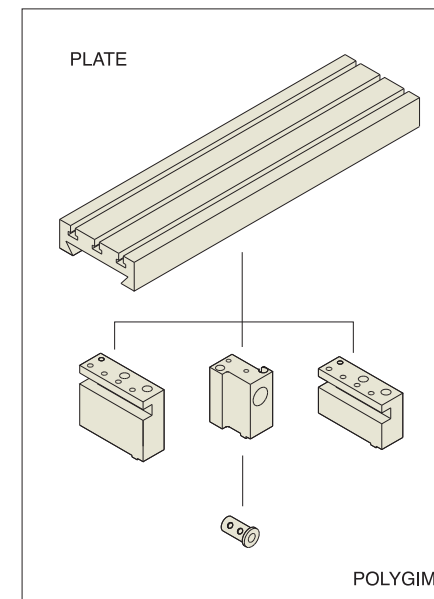

● 刀塔 TURRET

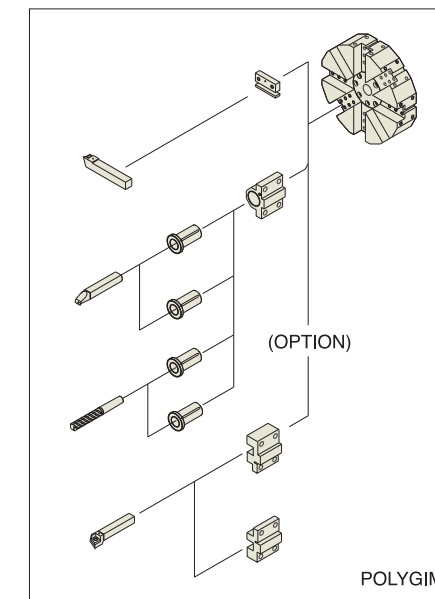

● 加工範圍 WORKING RANGE

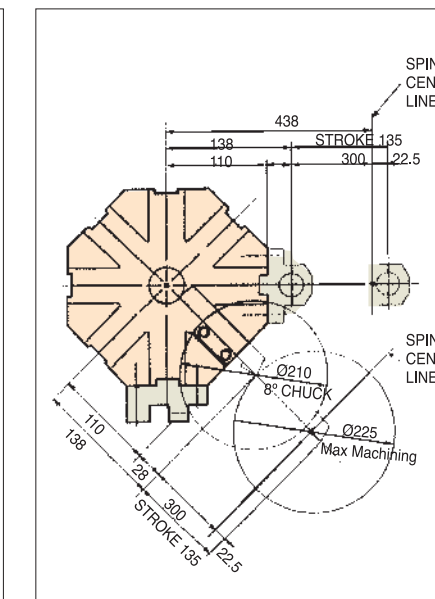

POLY GIM

電腦車床

CNC LATHE

Series

效率 · 經濟 · 精度

SIMPLICITY · PRECISION · SPEED · DURABILITY · STABILITY

POLY GIM



宝丽金(东莞)精密机械有限公司
Polygim(Dongguan) Precision Machinery Co., Ltd.

☎ +86 13717406410 微信同号
南方技術營運中心：廣東省東莞市常平鎮橫江廈工業三路1號
工廠：臺灣苗栗縣銅鑼鄉竹森村149之1號
https://www.polygim.cn E-Mail: caoyupin88@gmail.com

精簡的設計 · 人性化操作面板 · 非常適合量產加工！

方軌設計，讓重切削更容易！

SIMPLIFIED AND HUMANITY DESIGN IS SUITABLE FOR MASS PRODUCTION!

HIGH RIGIDITY DESIGN IS GOOD AND EASY FOR HEAVY CUTTING!



MODEL: **PLG-42**

- 1. 筒式刀座，讓換刀更快速、準確。 Gang type tool makes tool change easily.
- 2. 加寬的除屑機，讓除屑工作更容易。 Wide chip conveyor makes chip removal easily.
- 3. 可另行選購8支刀刀塔。 Optional 8-station turret, offer more flexible operation.
- 4. 工件收集器。 Part catcher offers automatic operation.

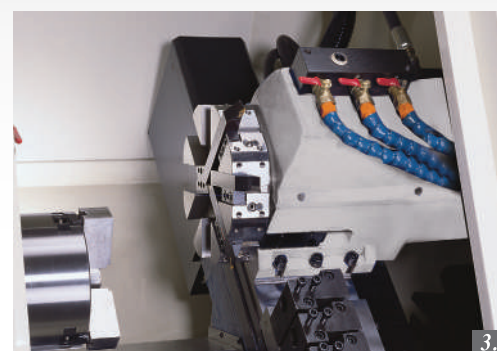

MODEL: **PLG-52
PLG-60
PLG-75**

高精度滾珠螺桿及軸承，確保您的精密加工。



成品輸送裝置
Part conveyor



尾座 Tail Stock
可程式頂針行程100mm
Programmable quill with stroke 100mm and MT4 taper.



排屑機 Chip Conveyor

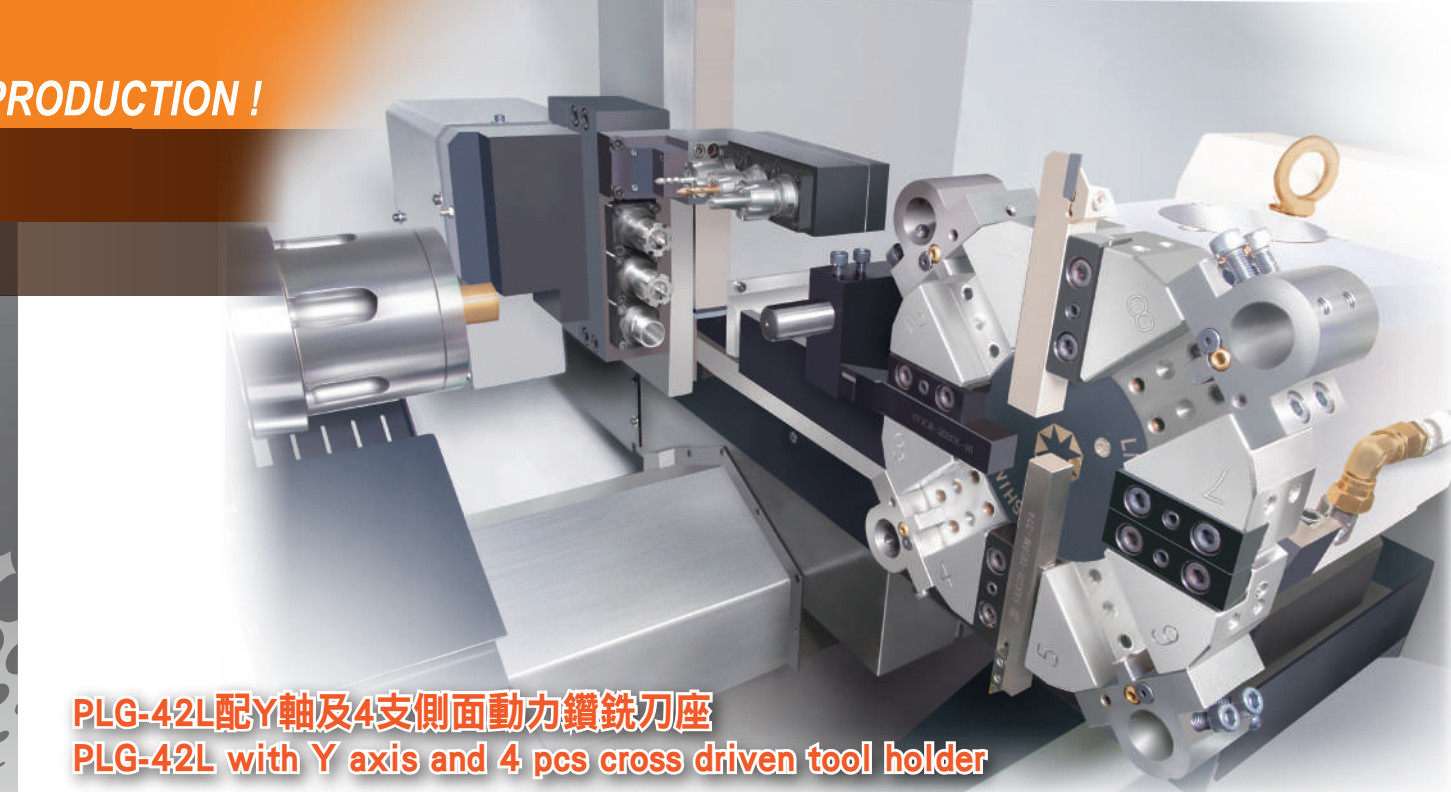

PLG-42L配Y軸及4支側面動力鑽銑刀座
PLG-42L with Y axis and 4 pcs cross driven tool holder

● 刀具配置 Tool configuration A

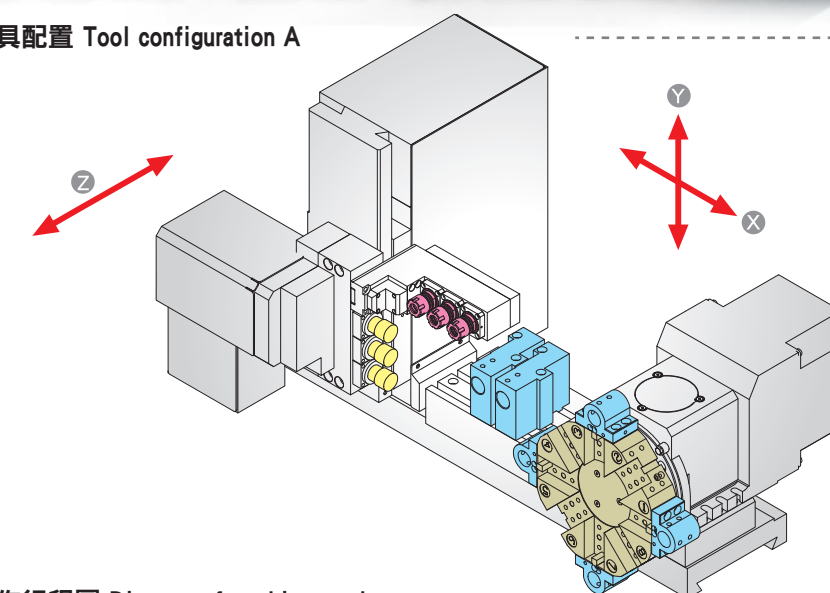

- 4支側面動力鑽銑刀座
4 pcs cross driven tool holder
 - 3個內孔刀座
3 pcs boring tool holder
 - 8角伺服刀塔 (選配)
8 stations servo turret (option)
 - 3支端面鑽銑刀座 (選配)
3 pcs off-center driven tool holder (option)
- 因選配端面鑽銑刀座，側面動力鑽銑刀座只能裝3支
Due to option the off-center driven tool holder, the cross driven tool holder can only install 3 pieces

● 工作行程圖 Diagram of working stroke

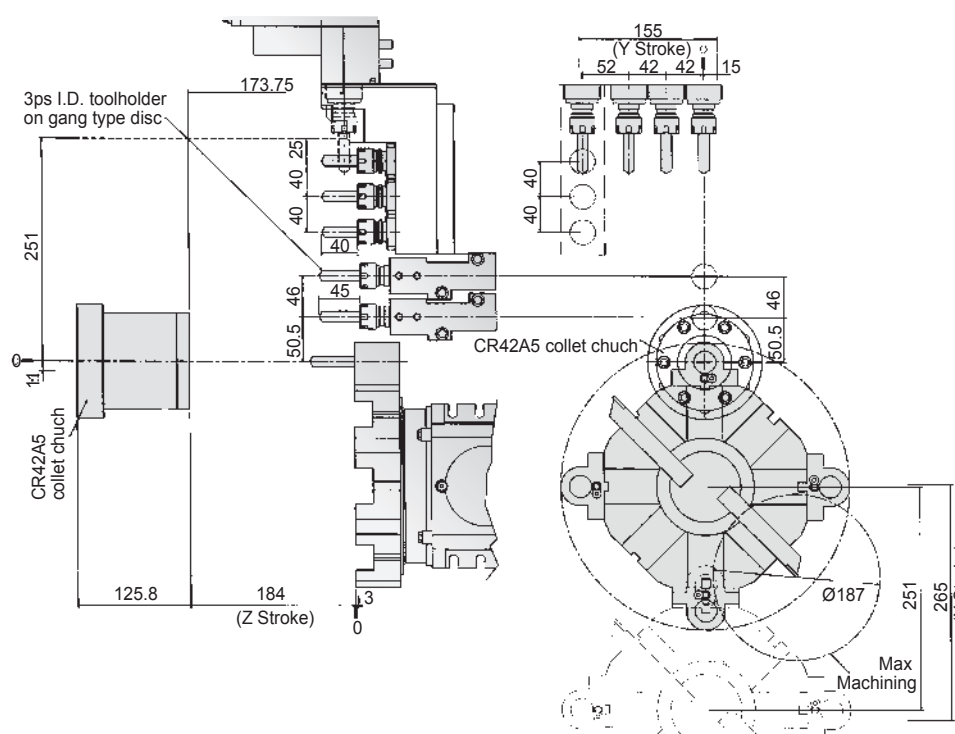

● 刀具配置 Tool configuration B

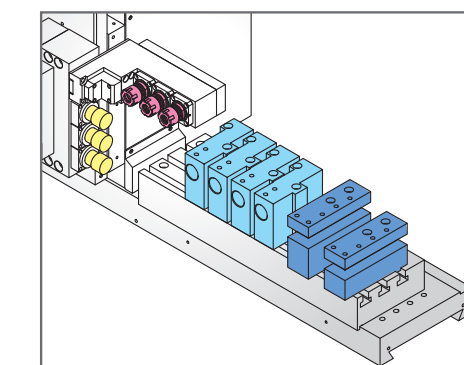

- 4支側面動力鑽銑刀座
4 pcs cross driven tool holder
 - 4個內孔刀座
4 pcs boring tool holder
 - 1個上刀座
1 pc O.D turning upper tool holder
 - 1個下刀座
1 pc O.D turning lower tool holder
 - 3支端面鑽銑刀座 (選配)
3 pcs off-center driven tool holder (option)
- 因選配端面鑽銑刀座，側面動力鑽銑刀座只能裝3支
Due to option the off-center driven tool holder, the cross driven tool holder can only install 3 pieces

“伺服馬達鑽孔機” Power Tool

動力鑽銑刀座可做多邊加工
Power tool holder can operate multilateral parts



MODEL: **PLG-42L**

油壓鑽孔機系列

配置專用油壓系統，可任選以下鑽孔機，做特殊鑽孔功能

Power Tools Series
Any of hydraulic parts below is optional accessory to satisfy users' every option.



側鑽單軸
Single-hole Side drilling holder



側鑽雙軸
Double-hole Side drilling holder



固定不動 Fixed holder

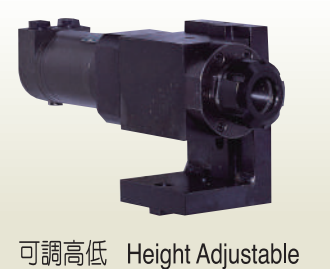

可調高低 Height Adjustable

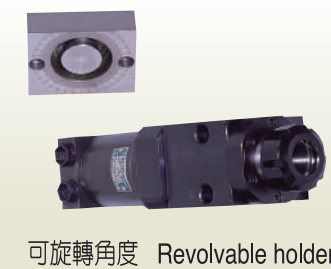

可旋轉角度 Revolvable holder